

2019

UKSEDS National Rocketry Championships 2019

DESIGN REPORT

SIMON A BETTS, CARDIFF UNIVERSITY, HIGH FLYERS

Table of Contents

1. Abstract	2
2. Introduction	2
3. HF-003	3
3.1. Nose Cone	3
3.2. Electronics	3
3.3. Body Tube	4
3.4. Fins.....	4
3.5. Rocket Motor	5
3.6. Parachute	5
3.7. Lunch Lug	5
3.8. Simulations.....	5
3.9. Finalising	6
4. Cost.....	7
5. Conclusion.....	8

Table of Figures

Figure 1: Electronics Layout.....	3
Figure 2: Cross Section of Rocket HF-003 (from tail forward ahead of fins)	4
Figure 3: HF-003 Fin Design	4
Figure 4: Simulation Components - HF-003.....	5
Figure 5: Simulated Rocket Layout - HF-003.....	6
Figure 6: Simulation Plots - HF-003	6
Figure 7: Simulation Results - HF-003.....	6

Table of Tables

Table 1: White Thunder Specifications	5
Table 2: Predicted Costs	7
Table 3: Actual Costs	7

1. Abstract

This report will outline the hard work being conducted by the team named the “High Flyers” at Cardiff University. It will detail the facts of the rocket known as ‘HF-003’ which comes in at 863.6 millimetres long with a diameter of 60.4 millimetres. It is anticipated that the rocket should reach an altitude of approximately 400 to 450 meters, with the full launch being complete within 60 seconds.

2. Introduction

There are many reasons for an individual and for a team to get involved in rocketry from the understanding of basic principle through to the fun and excitement of being able to launch one’s own rocket high in to the sky. During the last four months a small team from Cardiff University has been designing a rocket that will be launched at the ‘Sky Launch Centre’ in Monmouth by July 2019.

The rocket has been broken in to various sections in order to complete this report. The sections are, Nose Cone, Electronics, Body Tube, Fins, Rocket Motor, Parachute, Launch Lug, Simulation and Finalising.

3. HF-003

This section will form the main bulk of this report and will look at each of the rocket known as HF-003 components a part at a time. There will be a small amount of justification of the selection of the part and a summary of the simulations conducted on this particular rocket.

3.1. Nose Cone

For the nose cone the team decided to use the 80 Nose cone which comes in at 63mm (2.56in). Really it is at this point that it should be noted that the model rocket industry is still using primarily imperial units of measure. It is believed that this is due to the majority of parts coming to the UK are from the United States.

The selection of Nose cone was a direct result of the selection of body tube which will be discussed in section '3.3. Body Tube'.

3.2. Electronics

There are a variety of electronics that have been used. For rocket HF-003 the electronics weight is approximately 105 grams. The electronics includes a pressure sensor, SD Card Reader, Arduino Nano, Bluetooth Module, various cables and finally a power supply.

The Arduino Nano will be used in order to control the onboard electronic system. The pressure sensor will feed data relating the pressure, temperature and calculated altitude back to the Arduino. The data is saved directly to the SD Card via the SD Card Reader. The Bluetooth module will be used to initiate the data retrieval and temporarily validate the retrieval of data from the pressure sensor to the operator before launch.

Figure 1 shows the layout of the electronics being used and how they will connect to one another. It was important to note that the Arduino Nano is an open source piece of hardware and the selection of such a device was made so that the total cost of the project did not get overwhelming.

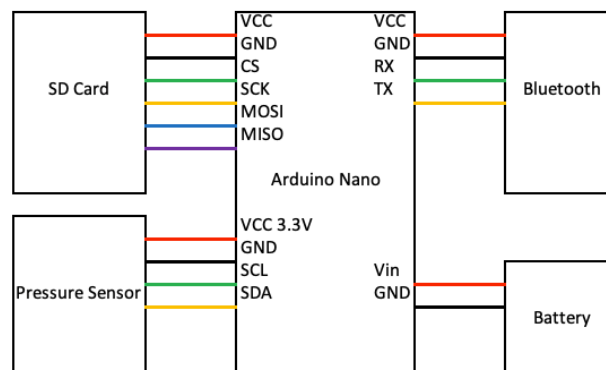

Figure 1: Electronics Layout

3.3. Body Tube

The body tube of the rocket is fundamentally the first building block of the rocket. For HF-003 a Body Tube 80 (Thick Wall) was used. This body tube comes in at 65mm diameter (2.56inch) and is 863.6 (34") long. The thick-walled version of this body tube will give the rocket more rigidity.

The reason for the selection of this body tube was to allow room for the mounting of the rocket motor inside of the body tube. Figure 2 shows the cross section of rocket HF-003. The red hatch section shows the plywood being used for mounting the rocket motor. The green hatch denotes the body tube walls. The plywood will be attached to the body tube using adhesives.

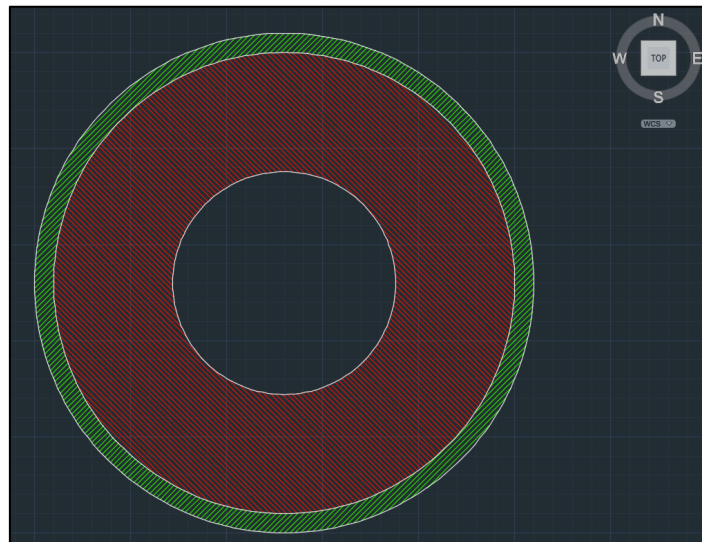

Figure 2: Cross Section of Rocket HF-003 (from tail forward ahead of fins)

3.4. Fins

HF-003 will have 4 fins spaced equally at 90 degrees to each other. These design of these 4 fins are shown in figure 3. The fins will be made from "Correx Fluted Board". This will be a light weight and durable material able to withstand the forces acting upon HF-003 during its flight.

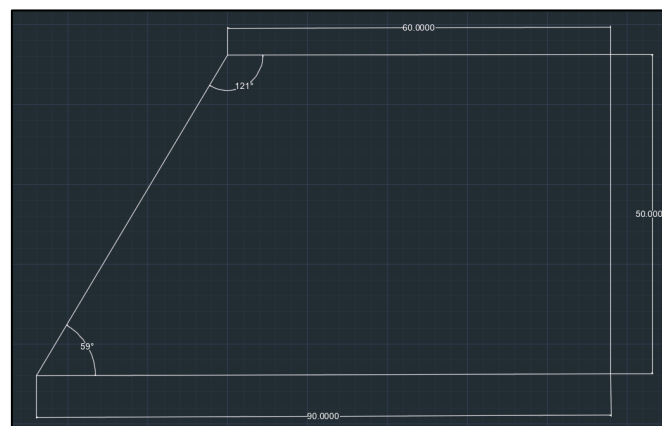

Figure 3: HF-003 Fin Design

3.5. Rocket Motor

The choice of rocket motor for HF-003 were limited by the race competition officials so that the rocket can only use the Cesaroni 29mm 2 grain rockets motors. There are quite the range of rocket motors in this category so HF-003 will be using the White Thunder rocket motors. These are the following rocket motor specifications:

Table 1: White Thunder Specifications

	Delay (Seconds)	Burn Time (Seconds)	Total Impulse (Newton Seconds)	Max Thrust (Newtons)
White Thunder	13	0.9	116.0	167.4

For the purposes of HF-003 a Cesaroni starter kit was purchased which provides the motor retaining system and delay adjustment tool.

3.6. Parachute

For the parachute a 24inch Nylon rip stop Parachute in RED will be used. This will attach to the rocket via 3.175mm (1/8 inch) tubular Kevlar. The Kevlar cord will attach to the HF-003 via a 6mm quick link and 4.67mm (3/16 inch) 130lb Eyebolt.

The parachute system really wouldn't be complete without discussing the delay time between launch and the deployment of the parachute, this will be covered later in section 3.8 with the simulation of HF-003.

3.7. Launch Lug

The launch lug is a small item that is often forgotten about when reporting. Due to the relatively small size of HF-003 the launch lug will be made of a 20mm piece of nylon tube. This tube will be slotted on to the launch platform ready for launch. The tube is fixed to the rocket body via adhesive.

3.8. Simulations

It is to be noted that the open source software 'Open Rocket' has been used for all simulations used throughout this project. This is open source software that can be located at <http://openrocket.info>. This rocket simulator has yet to be verified by the 'High Flyers' but is trusted based on the reviews of other university teams and rocketry associations.

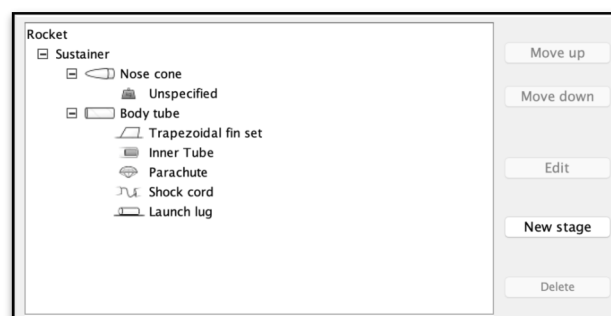

Figure 4: Simulation Components - HF-003

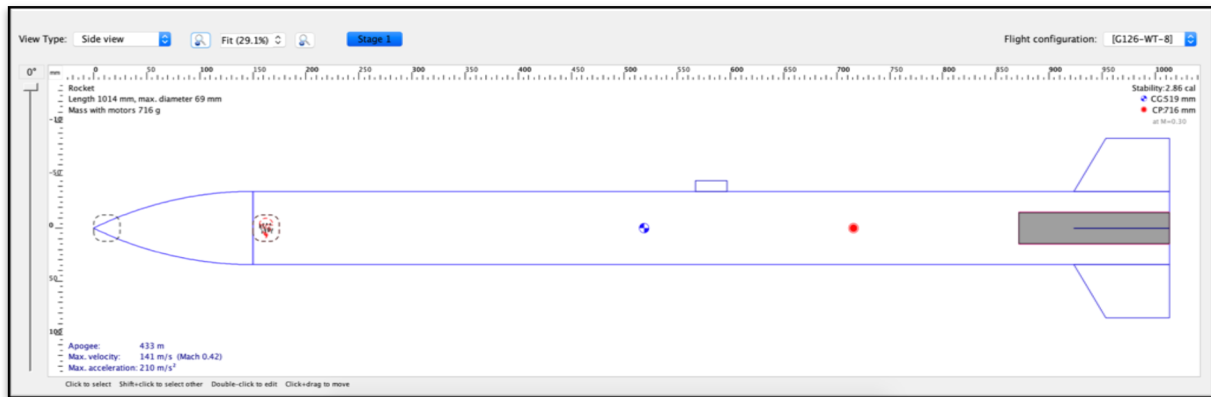

Figure 5: Simulated Rocket Layout - HF-003

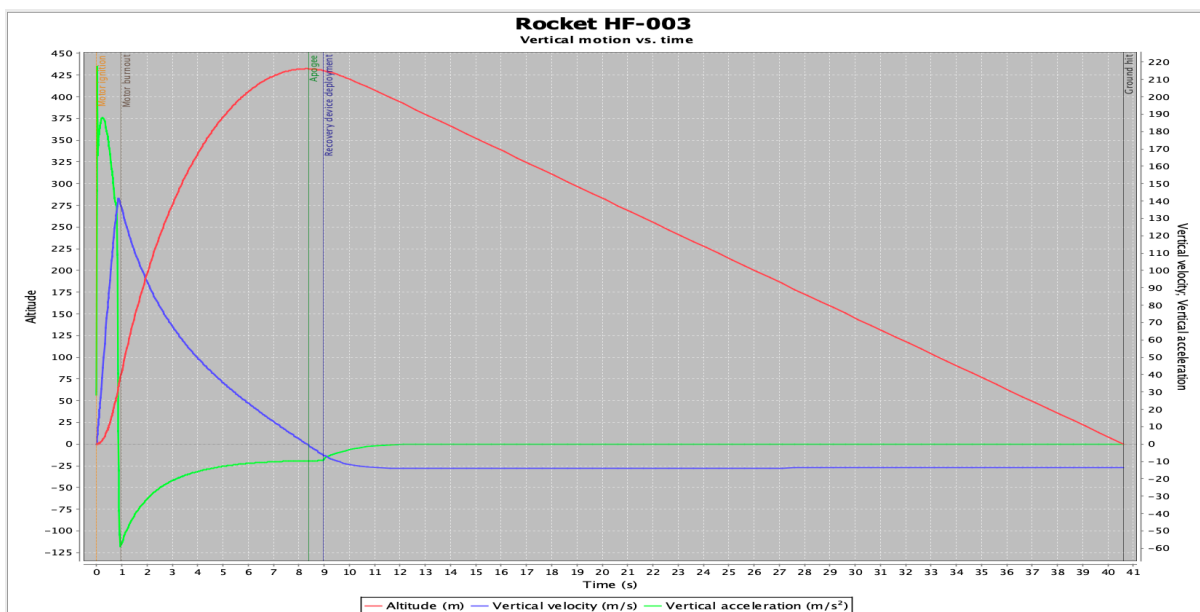

Figure 6: Simulation Plots - HF-003

Name	Configuration	Velocity off rod	Apogee	Velocity at depl...	Optimum delay	Max. velocity	Max. acceleration	Time to apogee	Flight time	Ground hit velo...
Simulation 1	[C126-WT-8]	19.6 m/s	432 m	6.25 m/s	7.41 s	141 m/s	217 m/s²	8.32 s	41.1 s	13.6 m/s

Figure 7: Simulation Results - HF-003

The simulation shows that HF-003 will reach an apogee of approximately 427 meters. The rocket will fly for a maximum of 41.1 seconds and reach its maximum apogee at approximately 8.32 seconds. The delay for the parachute has been set based on the results of this simulation. As the delay tool only has setting for 7 seconds or 9 seconds it has been decided that the delay for HF-003 will be initially set at 9 seconds.

3.9. Finalising

HF-003 will be finished with a bright pink and white colour scheme. The bright pink paint will aid in successful recovery of the rocket itself and increase its overall visibility. Additionally, there will be a Cardiff University logo and the rocket Identity on the exterior of HF-003.

4. Cost

For this project there have been two tracked costs, the predicted cost and the actual cost. There is only one predicted cost currently. All other associated costs have moved to the actual cost table. Currently the project cost is totalled at £234.16 with a breakdown of these cost in Table 3.

Table 2: Predicted Costs

Product	Cost	Quantity	Total
3D Printing (Electronics Mount)	N/A	N/A	N/A
		Total:	-----

Actual Costs

Table 3: Actual Costs

Product	Cost	Quantity	Total
Hackspace Magazine (Issue 12, How to Build a Rocket)	£6.00	1	£6.00
Plywood	£10.08	1	£10.08
Pressure Sensor (3 pcs)	£5.95	1	£5.95
Arduino Nano (3 pcs)	£6.18	1	£6.18
SD Card Reader (5 pcs)	£8.19	1	£8.19
Bluetooth Module	£3.57	2	£7.14
Heat Shrink Tubing (127 pcs)	£2.04	1	£2.04
Heat Shrink Tubing (328 pcs)	£2.65	1	£2.65
Body Tube 80 Thick Walled 34"	£7.50	3	£22.50
Fins	£2.93	1	£2.93
Nose Cone 80	£6.50	1	£6.50
Parachute 24inch Rip Stop Nylon	£12.50	1	£12.50
1/8 inch Tubular Kevlar	£1.00	3	£3.00
6mm Quicklink	£3.75	1	£3.75
3/16 inch Eye Bolt 130lbs	£1.75	3	£5.25
CESARONI 29MM 2-GRAIN White Thunder	£21.50	3	£64.50
CESARONI 29MM RELOADABLE MOTOR STARTER SET	£55.50	1	£55.50
Shipping	£9.50	1	£9.50
		Total:	£234.16

5. Conclusion

HF-003 is the third iteration of design for the rocket team known as the 'High Flyers'. The rocket is hoped to be launched at the Sky Launch Centre in Monmouth, South Wales by the beginning of July. As confirmed by the simulations the HF-003 should reach a theoretical apogee of 432 meters $\pm 10\%$.

Really it is the principle aim of the team to learn how to design, build and launch a rocket, meaning that in the future HF-XXX can be built to optimise the principle of rocket flight and maximise apogee. Additionally, and more fundamentally the team was put together to enjoy the process of learning as opposed to competing to achieve the lightest, highest flying rocket.